



Estimation of directivity and sound power levels emitted by aircrafts during taxiing, for outdoor noise prediction purpose

C. Asensio *, I. Pavón, M. Ruiz, R. Pagan, M. Recuero

Grupo de Investigación en Instrumentación y Acústica Aplicada (I2A2), Universidad Politécnica de Madrid, Ctra. de Valencia, km 7, 28031 Madrid, Spain

Received 28 March 2006; received in revised form 11 July 2006; accepted 12 July 2006
Available online 19 October 2006

Abstract

Integrated noise model (INM) is the most internationally used software to calculate noise levels near airports. Take off, landing or pass by operations can be modeled by INM, but it does not consider aircrafts taxiing, which, in some cases, can be important to accurately evaluate and reduce airports' noise assessment.

Aircraft taxiing noise emission can be predicted using other prediction tools based on standards that describe sound attenuation during propagation outdoors. But these tools require data inputs that are not known: directivity and sound power levels emitted by aircraft during taxiing.

This paper describes methods used to calculate directivity indexes and sound power levels, based on field measurements made in Madrid-Barajas Airport (Spain). Obtained results can be used as inputs for general purpose outdoor sound prediction software, which will be able to evaluate noise at airports vicinity as industrial noise.

Directivity and sound power levels have been estimated in octave and third octave band terms, for several aircraft families.

© 2006 Elsevier Ltd. All rights reserved.

Keywords: Aircraft taxiing; Sound; Noise; Noise assessments; Sound propagation outdoors; Sound power level; Ground; Airport; INM

* Corresponding author.

E-mail address: casensio@i2a2.upm.es (C. Asensio).

1. Introduction

Acoustic pollution is a reason for concern because of its severe annoyance and its effect on health, human behavior and community activities [10]. That is evidenced by the fact that most reports and complaints in environmental areas are related to sources which emit excessive and disturbing noise or vibrations.

Moreover, noise costs are dominant in environmental costs of aviation [1,2]:

- It is a cause of depreciation in house prices, so it affects owners.
- Land use near airports is limited to non-acoustic sensitive uses during the planning stage. So housing regions cannot grow. This has an important cost for local authorities.
- Affected dwellings need to be protected from noise pollution. That has a cost for national airport authorities.
- These costs will have repercussions in flight prices for passengers.

As a main tool for fighting noise, it needs to be requested that noisy activities are checked to prove that the emitted noise levels do not exceed established limits.

Airport activities, which are related to high noise emission levels, can be grouped in four main categories:

- Flight operations: take-offs and landings.
- Taxiing.
- Maintenance operations.
- Road traffic access to the airport.

During the planning stages, when noisy activity has not been implanted or while evaluating operation changes, it is necessary to find a noise mapping prediction tool for future scenarios. When an activity is already implanted, it is possible to describe its noise assessment using measurements, but this is expensive, so prediction tools can also be useful.

Flight operation noise can be modeled using INM. There are several models to predict road traffic noise [5]. But there are no specific tools to model taxiing and maintenance operations, so they must be accommodated to general purpose outdoors noise prediction software (ONPS). The European Commission WG-AEN [14] recommends that aircraft taxiing “should be considered as industrial noise and mapped accordingly so that the full impact of all the noise sources at these airports can be assessed”.

ONPS evaluates sound attenuation during its propagation outdoors using as input data the sound power level emitted by noise sources, ONPS can calculate sound exposure levels at receptors. These useful tools include noise sources, buildings, barriers, ground effect, air attenuation, and all the terms with influence in sound propagation.

The objective of this investigation is to create a database of inputs that can be used with ONPS to evaluate noise assessment of aircraft taxiing movements and community noise exposure levels.

2. Sound power levels

ISO 3744 [6] describes a procedure used for estimation of sound power level emitted by a noise source using sound pressure level measurements in a free field over a reflecting surface. The main steps in the procedure are:

- A measurement surface grid must be defined to envelope the noise source.
- Grid dimensions are defined in the standard.
- The grid is used to locate microphone positions.
- Linear averaged third octave band spectra must be measured for all microphone locations.
- Averaged surface sound pressure levels can be calculated.
- Third octave bands sound power levels are obtained and can be A-weighted to obtain overall levels.

For most sources, applying this standard can be very simple, but when applying it to aircrafts, there are some specific circumstances to take into account:

- Aircrafts are a very big noise source, so it would be necessary to have a huge test platform to allocate to the aircraft.
- The aircraft movement is the studied noise source, so a piece of a runway has to be considered in which the moving aircraft is the noise source [9]. This increases the complexity of the test platform because it is necessary to let the aircraft go in and out of the platform. Microphone positions cannot be defined in those surfaces crossing the aircraft path.
- Security and safety standards in airports do not allow installing any kind of needed infrastructure.

Because of all the above reasons, it was necessary to modify the standard so that it could be effectively used for the estimation of sound power levels emitted by aircraft movements in land. This is the ISO 3740 [6–8] based method.

We have also tried another alternative method based on inverse engineering implemented in ONPS. This method uses the ISO 9613 [3,4] standard to calculate sound attenuation, which allows finding requested sound power levels from measured sound pressure levels.

2.1. Measurement platform

Airport's operation, security and safety standards make it impossible to control many of the conditions referred to the test platform. So it was necessary to find a location that fits the following requirements:

- It must be a location with a big amount of aircraft movement from different families.
- There must be minimum background noise levels, so that the aircraft land movements are the main noise source registered in the measurements.
- The measurement process must guarantee the observance of aircraft's operation, and security and safety standards.

- The test platform must be an open area, free of buildings and other obstacles, so the condition of free field over a reflection surface can be considered.
- In the test field, every aircraft has to travel across a straight line with constant low speed so it is possible to have long enough measurements.
- Aircraft's operation in the test platform has to be representative of aircraft operations during taxiing.

Airport authorities suggested a 200-meter area where all these requirements could be met. Only taxiing operations before taking-off could be registered in this platform.

2.2. *Microphone positions*

Microphone positions were chosen to fulfill the ISO 3740-based method requirements. A surface was defined whose dimensions are fixed by the width and length of the selected piece of runway and whose height is related to each family of planes. This surface covers the source for the whole studied period (ISO 3744 reference surface).

For safety reasons it was required to separate the measurement box 22,5m from the reference box.

Because of the movement of the noise source inside the reference box as well as the size of the measurement box, it was necessary to simplify the grid which defines the measurement positions. Other restrictions were:

- It was not possible to locate any position over the aircraft.
- It was not possible to locate any position at the front or back of the box.
- It was not possible to use measurement heights over 4 m.

Five microphone positions were selected. They were parallel to the runway (see Fig. 1). The distance between microphones was 25 m.

The first microphone was 25 m far from the beginning of the reference box and the last one 25 m from the end. All the microphone positions were located in one lateral of the measurement box, as it is assumed that noise emissions are symmetrical with respect to the runway axis.

In order to get some information about vertical emissions, three microphones were located at a height of 2 m, and the other two were located at a height of 4 m above the ground. This is a necessary simplification, but most aircrafts have their engines at a height less than 5 m with symmetrical vertical emissions, so this simplification is considered a depreciable error.

2.3. *Equipment*

All equipment used in measurements had been calibrated in an accredited laboratory, and acoustic devices were verified in field.

- Sound analyzers: Brüel & Kjaer 2260.
- Sound calibrator: Brüel & Kjaer 4231.
- Meteorological station Oregon Scientific BAR898HG.

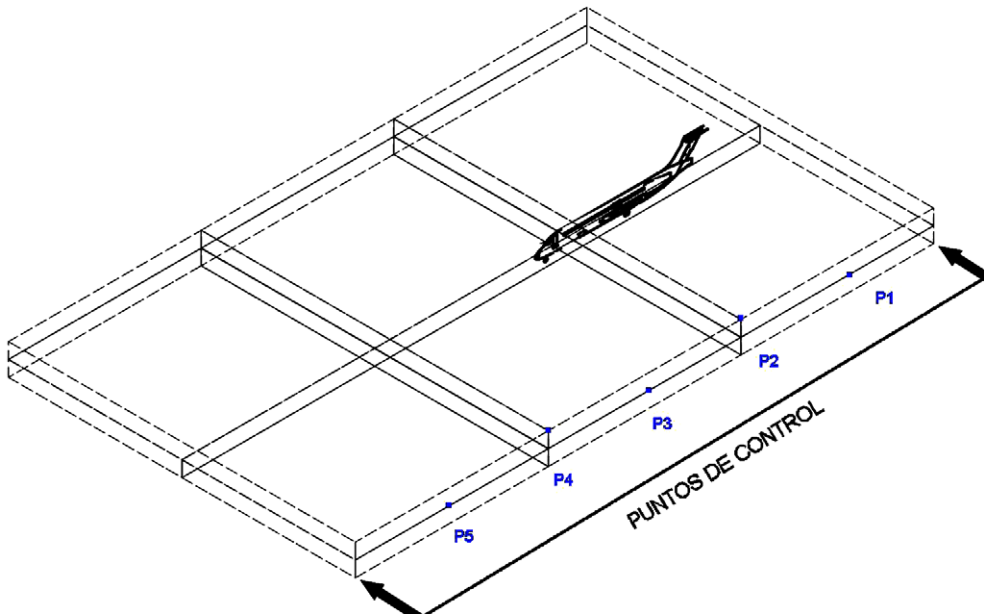

Fig. 1. Microphone locations.

2.4. Measurements

Five third octave band analyzers were used to register time history for spectra and equivalent noise level in 1 s intervals ($L_{Aeq,1s}$). All measurements were taken under ISO 1996 standards [12–14].

A technician was located at the beginning of the platform to trigger an event at the aircraft entrance. The trigger was registered in all the synchronized analyzers. While the aircraft was on the platform, every 1 s average spectra were recorded. Another technician at the end of the platform finished the event.

Technicians were responsible for discarding events because of background noise reasons (background noise could not be evaluated because of its randomness, so it was not possible to make any correction).

Measurements were made for three consecutive days in March of 2003, from 9.00 to 18.00 in Madrid-Barajas Airport. More than 300 events were measured.

2.5. Data processing

Several reasons made it impossible to use all the events measured, such as aircraft stops on the platform, other aircrafts near the platform, or other types of background noise. Only 240 events were used and classified into families.

Families were defined based on the aircraft model. By analyzing the obtained data, it was possible to do a further classification according to similar acoustic emissions of the models. The final classification appears in Table 1, in which the families and models are listed with the number of events used for the study.

Table 1
Aircraft families

Family	Models	Events
Family A-310-300		4
Family A-319		12
Family A-320		33
Family A-321	A-321-100 A-321-200	11
Family A-340-300		15
Family ATR-72-500		7
Family B-717		2
Family B-737-A	B-737-300 B-737-400 B-737-500	27
Family B-737-B	B-737-600 B-737-700 B-737-800	19
Family B-747		4
Family B-757-200		17
Family B-767	B-767-200 B-767-300	16
Family CRJ	CRJ-100 CRJ-200	9
Family DHC-8Q3		12
Family FOKKER 50		3
Family MD-82		12
Family MD-83		8
Family MD-87		13
Family MD-88		6

Measured spectra were classified by families and microphone position. Then a statistical criterion (Chauvenet) [11] was used to discard those spectra whose deviation from the media was too big.

Classified spectra were power averaged to calculate the average spectra for every microphone position.

For the ISO 3740-based method, five obtained spectra were power averaged. The resulting spectrum is assumed to be the averaged measurement surface spectra. The procedure described in the ISO 3744 for free field conditions over a reflective plane was applied to calculate third octave band sound power levels.

An acoustic model was created for the ISO 9613-based method where the aircraft movement is included as several omnidirectional point noise sources over a concrete surface. The model includes receiver positions, temperature, relative humidity, and ground effect. Averaged sound pressure spectra were assigned to each receiver and calculation parameters were defined to make an ISO 9613 inverse calculation.

2.6. Results

Third octave band sound power levels were calculated using the ISO 3740-based method. The ISO 9613-based results were expressed in octave bands terms.

Table 2
Sound power level – L_w (dBA)

Family	ISO 3740	ISO 9613	Difference
A-310-300	128.7	129.2	−0.5
A-319	125.7	125.7	0.0
A-320	126.3	125.6	0.6
A-321	125.2	125.5	−0.3
A-340-300	129.7	129.5	0.3
ATR-72-500	132.6	132.6	0.0
B-717	127.8	129.2	−1.4
B-737-A	130.8	130.3	0.5
B-737-B	127.4	126.0	1.4
B-747	133.4	134.2	−0.8
B-757-200	131.5	133.0	−1.5
B-767	129.4	130.3	−0.9
CRJ	123.4	124.8	−1.5
DHC-8Q3	131.6	131.6	0.0
FOKKER 50	132.1	132.3	−0.1
MD-82	127.3	128.0	−0.7
MD-83	127.7	129.1	−1.4
MD-87	126.6	127.6	−1.0
MD-88	127.5	128.2	−0.7

Table 2 shows overall A-weighted levels.

Both methods have obtained very similar overall results and even spectra are very similar, but some differences appear at high frequencies in spectra (see Fig. 2).

Emitted noise power levels (132.2 dBA) from propeller aircrafts are higher than those from jets (128.5 dBA), and both show a maximum level at 125 Hz octave band.

Although the results from both methods are very close, the use of ISO9613 is preferred, because it includes corrections for sound attenuation in the air. Because of this, there are some bigger differences at very high frequencies.

The spectra from jets are grouped in a range of approximately 15 dB (Fig. 3), but the spectra from propellers are very close in an approximately 3 dB range (Fig. 4).

3. Directivity index

Measure time histories were also used to calculate the directivity index of noise sources. The calculations have been made using the following considerations:

- Aircrafts move in a straight line with uniform speed over the axis of the platform.
- Spherical waves are emitted by the noise source.
- Directivity is symmetrical with respect to the axis of the aircraft, and it is possible to obtain results from just one side measurements (it was no possible to make both sides measurements because of safety reasons). So, only one side engine is included in the considered model.
- The considered sound source is located at the same distance from the front and back of the aircraft. It is located at the same distance from the longitudinal axis of the plane as the real engine. When the aircraft has two engines at the considered side, only one source has been located between both of them (Figs. 5 and 6).

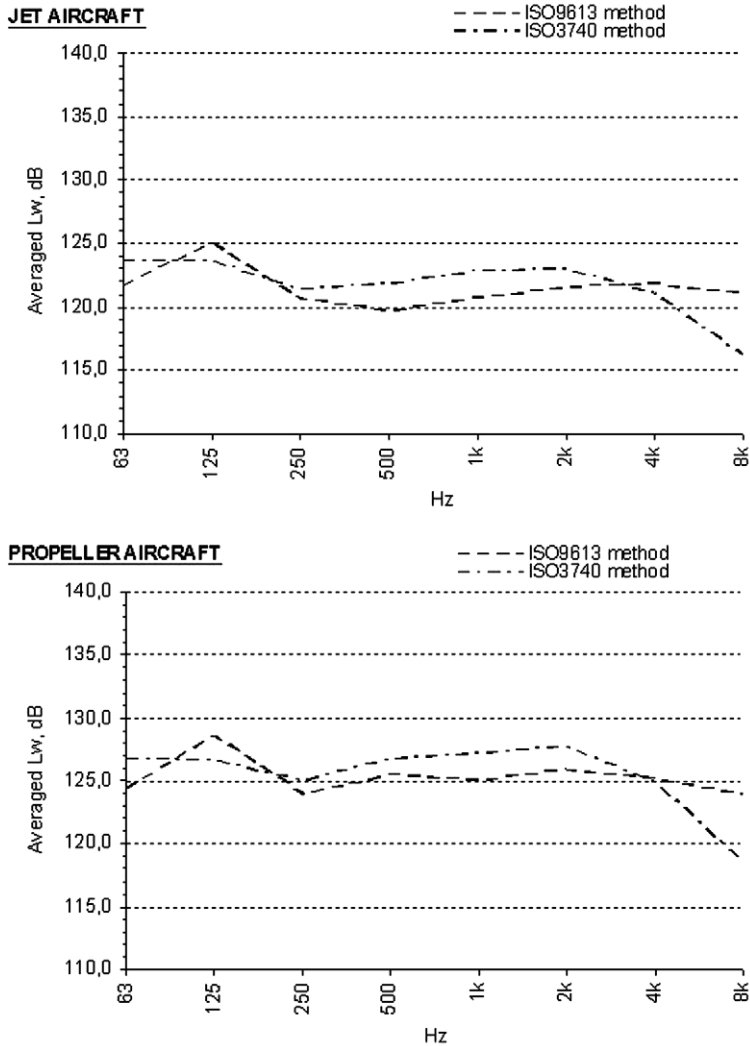

Fig. 2. Averaged L_w spectra comparison between two methods: (a) jet aircrafts; (b) propeller aircrafts.

We have measured third octave band sound pressure spectra in 1 s intervals while the aircraft is on the platform. For each frequency band, we can describe a function relating time history intervals and the angle between the axis of the aircraft and each microphone. So we can express measured levels against time or angle (Fig. 7).

ISO 9613 describes propagation of sound outdoors. It allows calculation of sound pressure levels at a receiver from sound power level of a noise source:

$$L_p = L_w - A_{div} - A_{atm} - A_{gr} - A_{bar} - A_{misc} \quad (1)$$

For each third octave band level, for each receiver, A_{gr} (ground effect) and A_{atm} (atmospheric attenuation) do not change while the aircraft is on the test platform; $A_{bar} = 0$ because no barrier is considered.

JET AIRCRAFT - ISO9613 based method

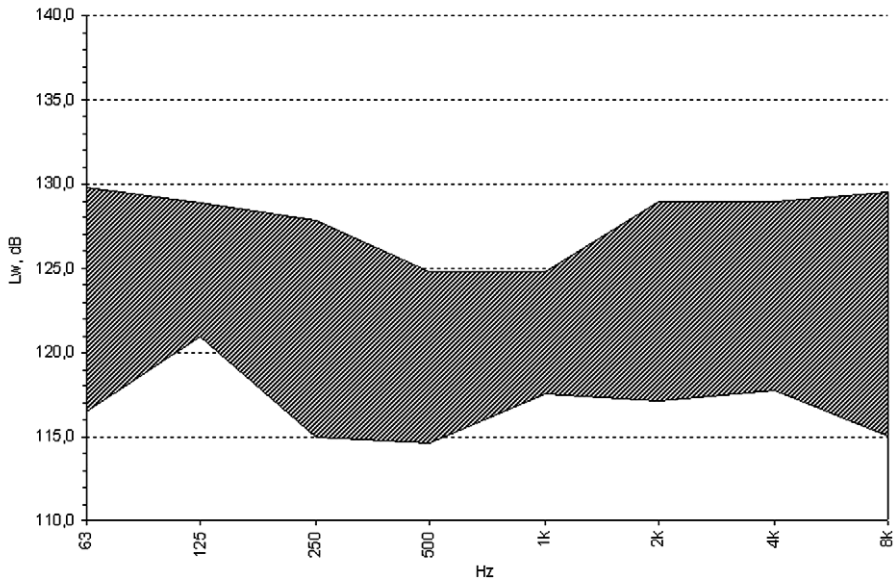

Fig. 3. Jet spectra ranges.

PROPELLER AIRCRAFT - ISO9613 based method

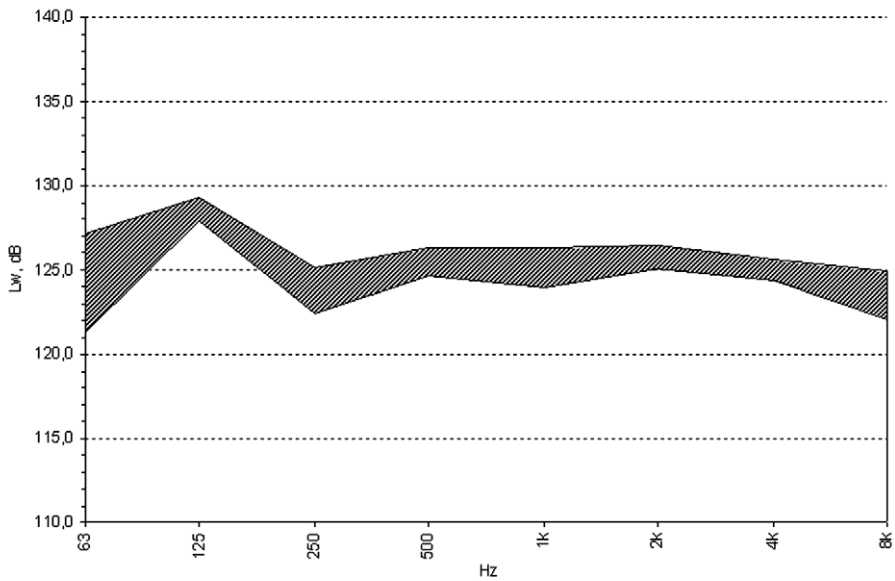

Fig. 4. Propeller spectra ranges.

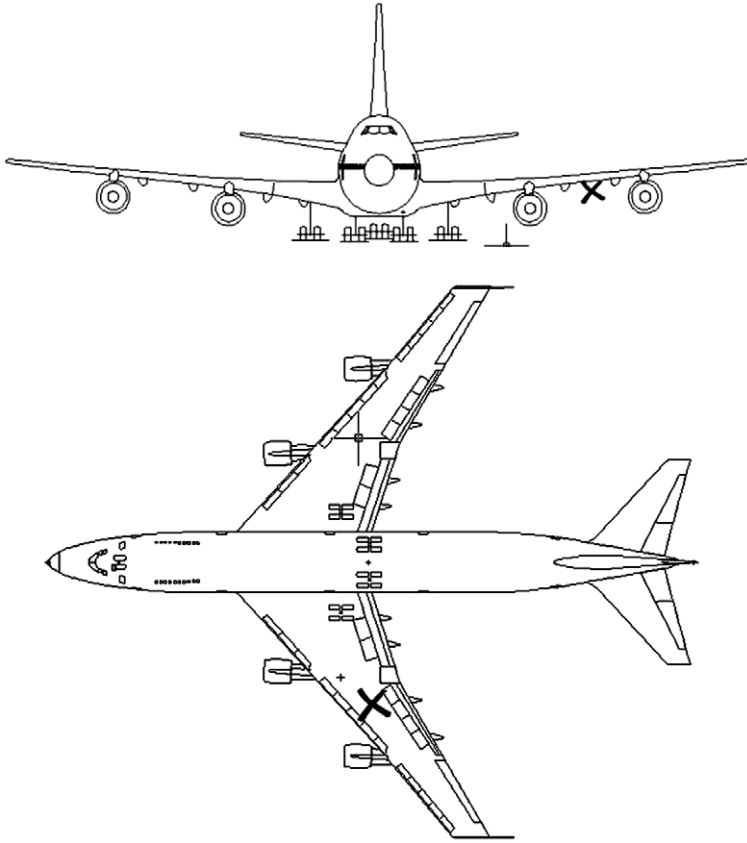

Fig. 5. Location of the noise source.

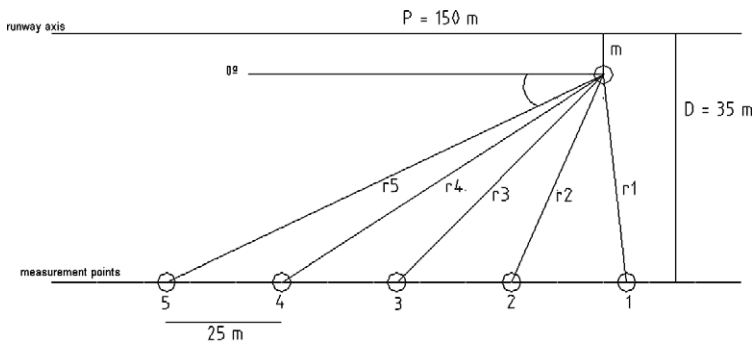

Fig. 6. Location of receivers and source path.

So we can define an equation for the distance (r) from each receiver to the location of the source along its path. We can calculate divergence attenuation, as defined in ISO 9613, using the calculated value of r .

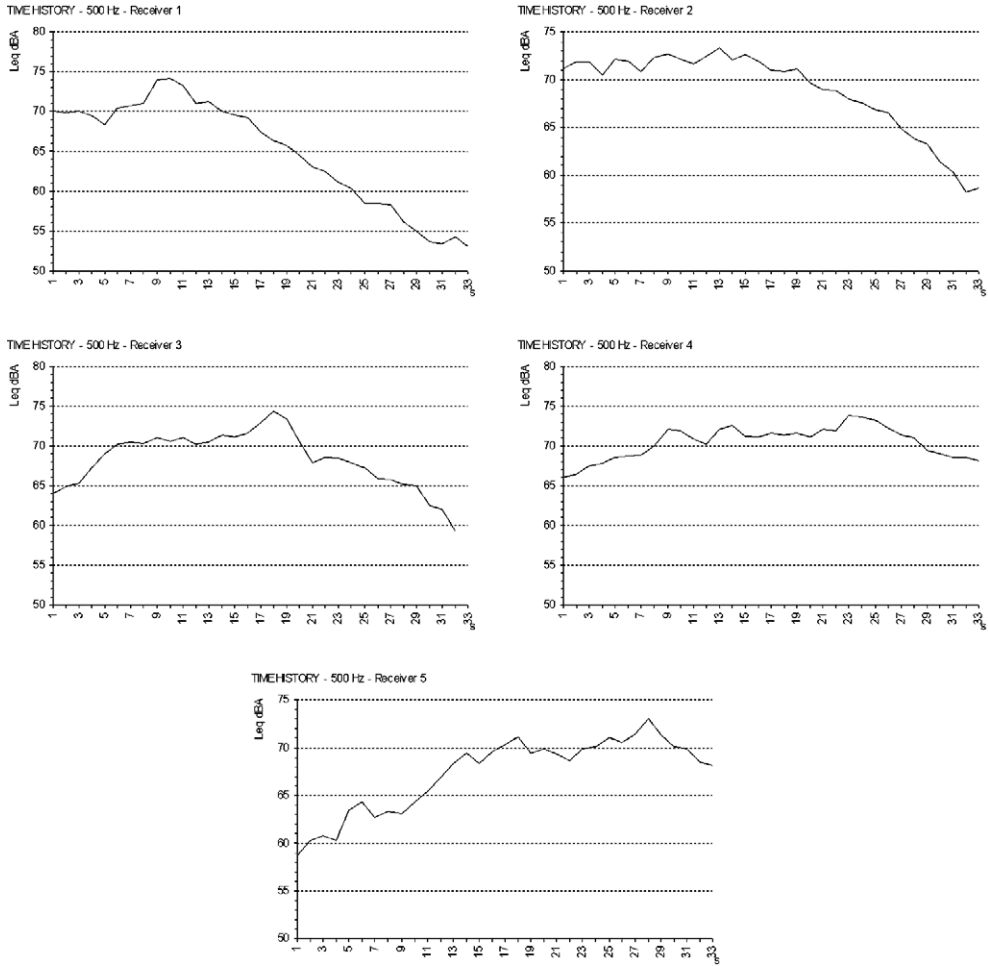

Fig. 7. Five hundred hertz third octave band time history.

$$A_{div} = 20 \log r + 11 \tag{2}$$

A_{div} is calculated for each microphone and for each position in the source path, which is related to an interval in the measured time history.

We must use calculated A_{div} to standardize measured band levels to a reference distance (the shortest distance between the source and the microphone).

After this correction, data for each receiver “have been measured at the same distance”. Every second measured level is related to an angle.

Now, we can merge the data pair series of every microphone. This new created series describes the aircraft directivity in an angle that ranges from approximately 20 to 160 degrees (angles nearer the axes can not be defined because of the receivers’ locations).

This process has been applied for every measured aircraft.

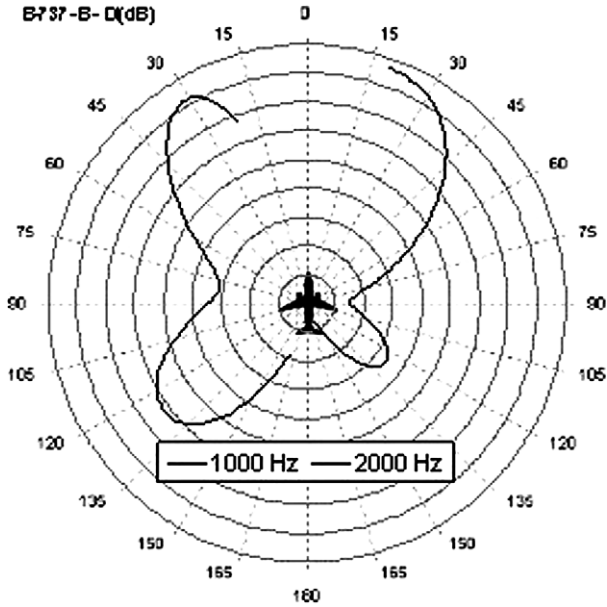

Fig. 8. Boeing 737-B family directivity index.

We have used an algorithm of interpolation for every data series (Householder, order 7). The obtained equations for each aircraft have been compared, for obtaining family directivity results.

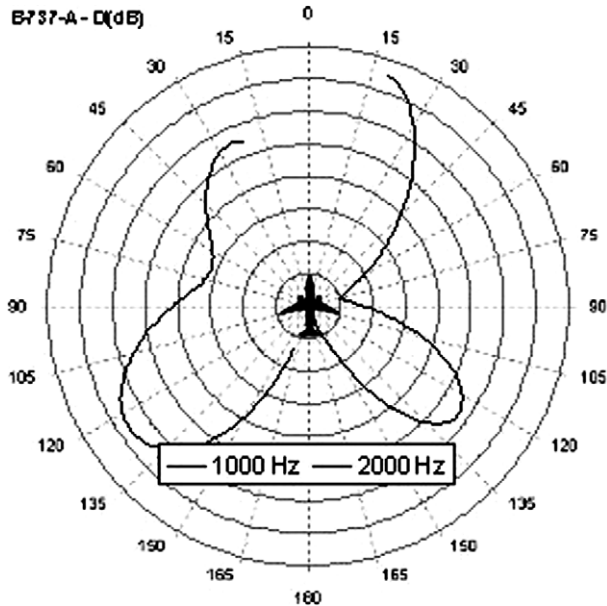

Fig. 9. Boeing 737-A family directivity index.

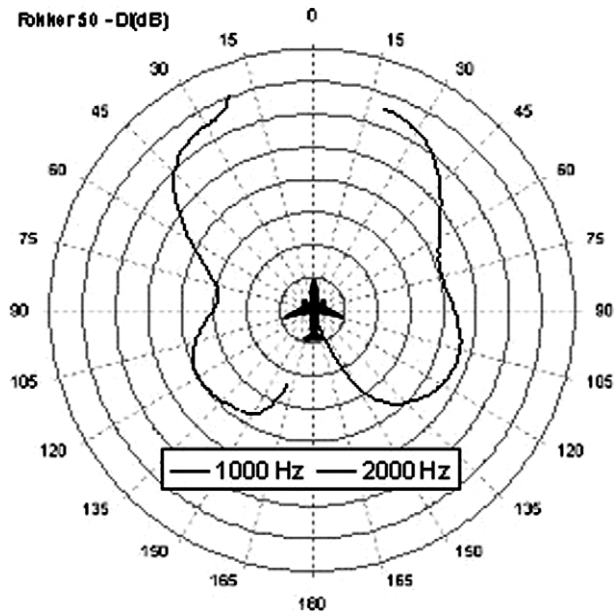

Fig. 10. Fokker 50 family directivity index.

Results have been expressed in polar charts for each frequency band, and data has also been expressed in tables for 5 degree intervals (using interpolated equations).

Figs. 8–10 show some results for some of the families at 1000 and 2000 third octave bands.

3.1. Propeller aircrafts

There are three propeller aircraft families in the study. All of them have a similar directivity pattern (Fig. 11). Low frequency emissions (below 200 Hz) have directivity indexes between +2 and –2 dB. For medium frequencies (from 200 to 1250 Hz), frontal emission increases and the emission perpendicular to movement direction decreases notably. At frequencies over 1250 Hz, back radiation is 4–10 dB lower than frontal or lateral, and the biggest directivity index appears at approximately 50°.

3.2. Jet aircrafts

Jet aircraft families cannot be so easily grouped because each one has different characteristics of the number of engines, size, location. We can conclude that low frequencies have bigger emissions to the back, but the directivity indexes are not big. High frequencies, however, have big directivity index in the front and lower directivity values in the back.

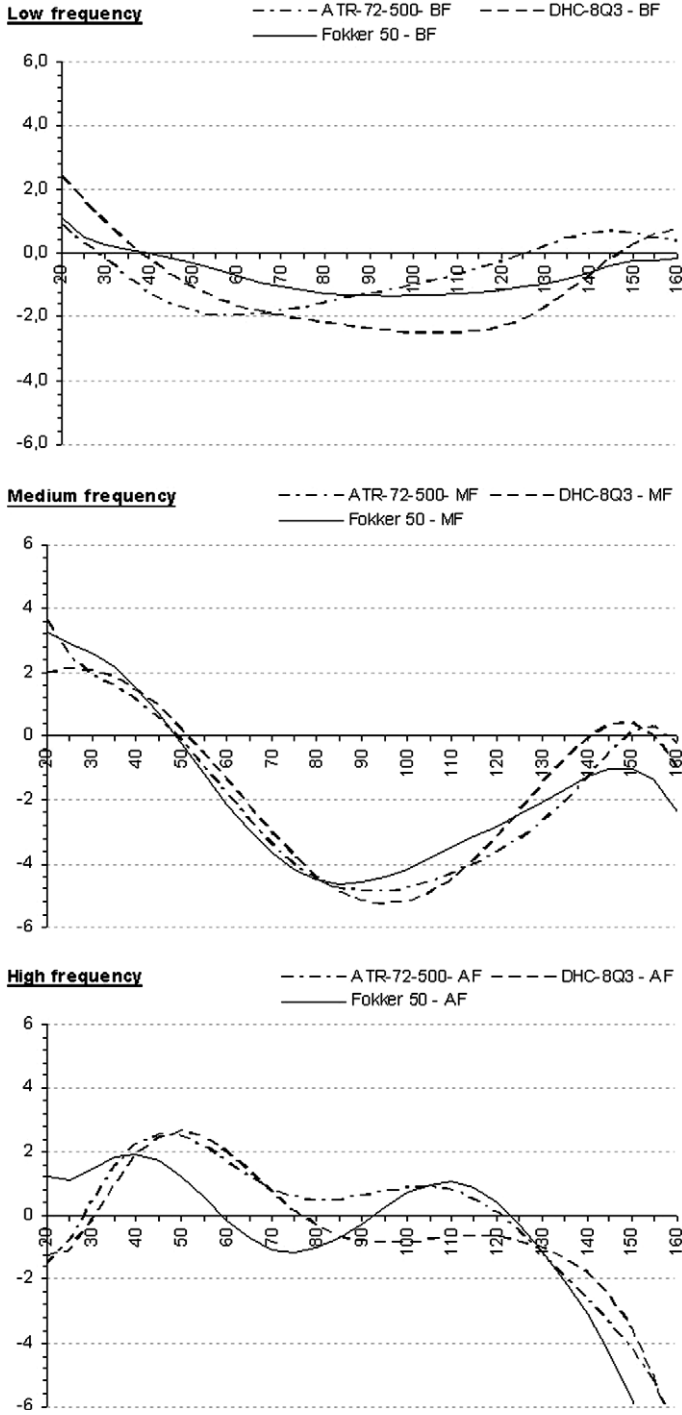

Fig. 11. Directivity index for low, medium and high frequency propeller aircrafts.

4. Discussion

4.1. Sound power levels

1. The ISO 3740 standardized methods cannot be applied to aircraft taxiing in an airport during regular operation. Because of this, some simplifications must be applied to standardized methods to fit safety and operational reasons.
2. Two different independent methods have been applied for estimating sound power levels (ISO 9613 and ISO 3740 based). Sound power level differences between methods are very small, so it has been demonstrated that assumed simplifications do not carry a big error.
3. Octave bands analysis shows some difference between results at high frequencies. The ISO 3740-based method results are lower at high frequencies than the ISO 9613-based results. This is caused by the effect of sound attenuation in the air, which is not considered by the ISO 3740 method because measurements are usually taken at a short distance. Above 5 kHz, attenuation coefficients are very big, so the distance between the source and the receiver produces a reduction in measured noise levels. This effect is considered by the ISO 9613 method, so there is an approximately 5 dB difference between both methods at 8 kHz octave band.
4. Sound power levels for all families vary from 125 to 133 dBA, with an averaged value of 128.9 dBA (both calculation methods have been considered) with a standard deviation of 2.8 dBA.

4.2. Directivity

5. A simplified model has been created to evaluate directivity indexes of aircrafts using ISO 9613.
6. Time history spectra had to be recorded.
7. It was not possible to get any measurement in the axis of the runway. For this reason, no results are available for 0°–20° and 160°–180°.
8. Propeller aircraft families show similar results. Low frequency emissions are quite omnidirectional. Medium frequency emissions have lower values at 90°. High frequency frontal emissions are bigger than lateral or back emissions.
9. Jet families have big differences in the number of engines, location of engines, size of the aircraft, so directivity results are different between families.
10. High frequency frontal emissions in jet aircrafts are much bigger than back emissions. Low frequency back emissions are bigger.

4.3. General

11. In Madrid-Barajas Airport, there are over 415,000 flight operations per year. Approximately 91% (see Table 3) of aircraft operations involved can be modeled according to the family classification presented in this paper.

Table 3
Distribution of operation at Madrid-Barajas Airport

	Percentage		Percentage
Family A-310-300	1	Family B-757-200	5
Family A-319	5	Family B-767	2
Family A-320	22	Family CRJ	7
Family A-321	5	Family DHC-8Q3	4
Family A-340-300	4	Family FOKKER 50	0
Family ATR-72-500	2	Family MD-82	4
Family B-717	1	Family MD-83	4
Family B-737-A	4	Family MD-87	6
Family B-737-B	9	Family MD-88	5
Family B-747	1	Others	9
Total		100	
Described		91	

Table 4
Line source sound power level for studied runway

	63	125	250	500	1k	2k	4k	8k
Lw, dB/m	91	94	89	89	90	90	91	90

12. Most aircrafts moved with an approximately constant speed of about 8–12 m/s. Averaged speed was 10.2 m/s.
13. Calculated data can be used in outdoors noise prediction software creating a model of several point sources or a single line source. It is necessary to include in the model corrections which take into account parameters not described in this paper, such as the number of operations of each family, paths, speed, event duration, and the studied period for calculations.

Madrid-Barajas airport statistics show about 570 taxiing operations every day in the studied runway. After applying the mentioned corrections, we can predict long-term equivalent noise level ($L_{Aeq,24h}$) for the studied runway using ONPS. The runway must be modelled using a line source which sound power level spectrum is shown in Table 4.

Acknowledgements

Data available in this article are property of Aeropuertos Españoles y Navegación Aérea (AENA). The authors are very grateful to AENA for sponsoring this investigation.

References

- [1] Schipper Youdi. Environmental costs in European aviation. Department of Development Economics, Vrije Universiteit: De Boelelaan, Amsterdam; 2003.
- [2] Schipper Youdi, Rietveld Piet, Nijkamp Peter. Airline deregulation and external costs: a welfare analysis. Department of Spatial and Environmental Economics, Free University: Amsterdam; 2002.
- [3] ISO 9613-1:1993 Acoustics – Attenuation of sound during propagation outdoors – Part 1: Calculation of the absorption of sound by the atmosphere.
- [4] ISO 9613-2:1996 Acoustics – Attenuation of sound during propagation outdoors – Part 2: General method of calculation.

- [5] CERTU, SETRA, LCPC, CSTB. Bruit des infrastructures routières. Méthode de calcul incluant les effets météorologique. NMPB Routes 96.
- [6] ISO 3744:1994. Acoustics – Determination of sound power levels of noise sources using sound pressure – Engineering method in an essentially free field over a reflecting plane.
- [7] ISO 3746:1995 Acoustics – Determination of sound power levels of noise sources using sound pressure – Survey method using an enveloping measurement surface over a reflecting plane.
- [8] ISO 3740:2000 Acoustics – Determination of sound power levels of noise sources – Guidelines for the use of basic standards.
- [9] Alfaro Degan G, Colasanti D, Pinzari M. Noise impact evaluation from moving sources. University Roma; 2003.
- [10] Directive 2002/49/EC of the European parliament and of the council of 25 June 2002 relating to the assessment and management of environmental noise.
- [11] Young HD. Statistical treatment of experimental data. New York, NY: McGraw-Hill; 1962.
- [12] ISO 1996-2:1987 Acoustics – Description and measurement of environmental noise – Part 2: Acquisition of data pertinent to land use.
- [13] ISO 1996-3:1987 Acoustics – Description and measurement of environmental noise – Part 3: Application to noise limits.
- [14] European commission working group – Assessment of exposure to noise (WG-AEN). Good practice guide for strategic noise mapping and the production of associated data on noise exposure. WG-AEN 002.2006 (final draft).